

DIMENSIONS						
REF.	mm			inch		
	MIN.	TYP.	MAX.	MIN.	TYP.	MAX.
A			1.2			0.047
A1	0.05		0.15	0.002		0.006
A2		0.9			0.035	
b	0.17		0.27	0.0067		0.011
c	0.09		0.20	0.0035		0.0079
D	12.4		12.6	0.488		0.496
E8		.1			0.318	
E1	6.0		6.2	0.236		0.244
e		0.5			0.0197	
K0	°		8°	0°		8°
L	0.45		0.75	0.018		0.030



48-LEAD THIN SHRINK SMALL OUTLINE

Weight: not available



TSSOP48

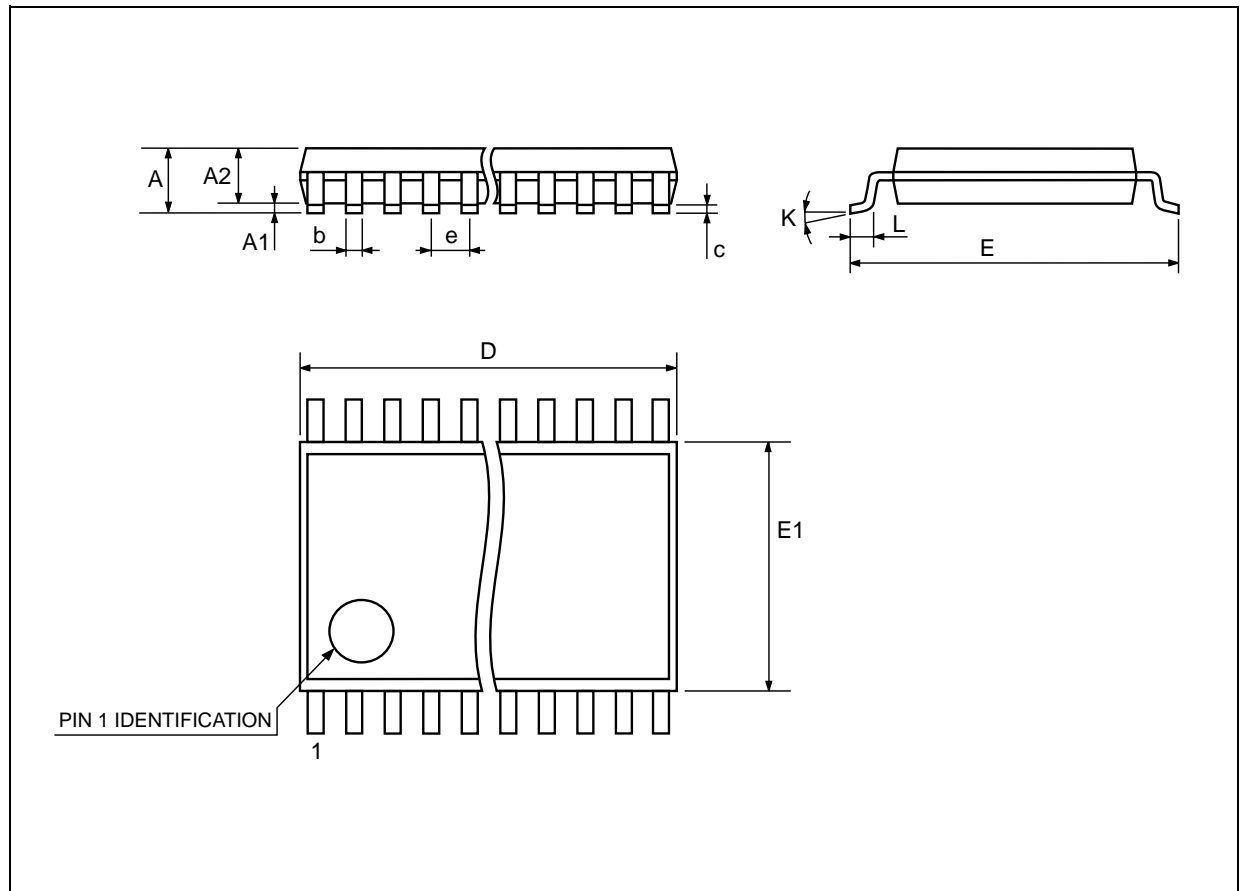

TAPE & REEL SHIPMENT INFORMATION
 TAPE SPECIFICATIONS

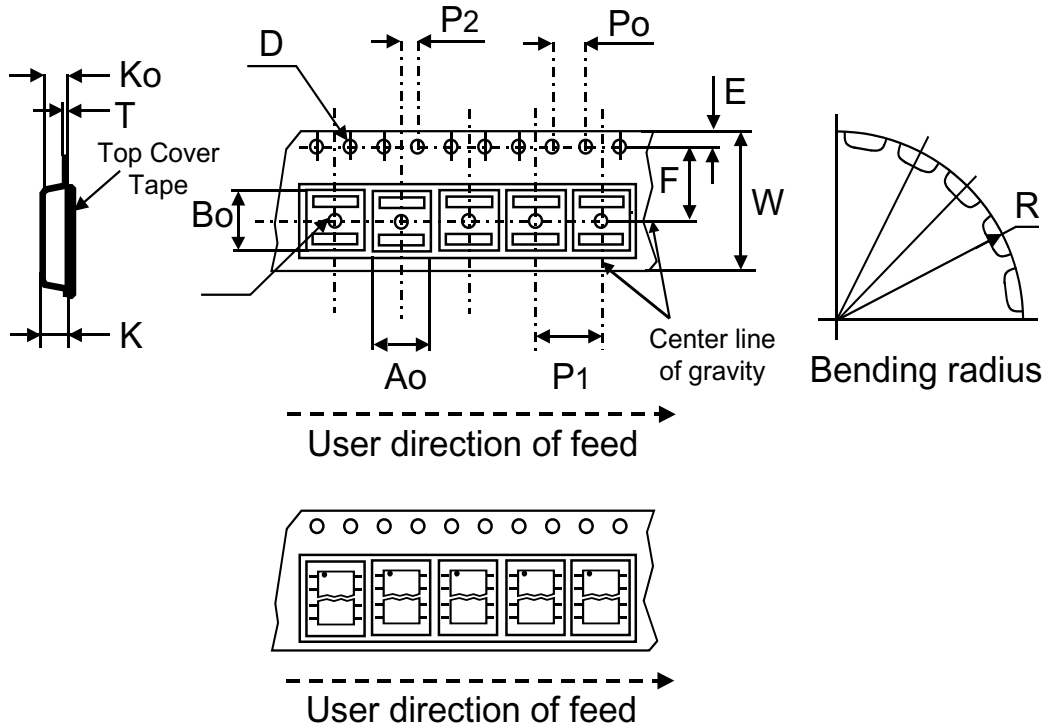

TAPE MECHANICAL DATA		
	mm.	inch
D	1.50 +0.1/0	0.059 +0.004/0
E	1.75 ±0.1	0.069 ±0.004
Po	4.00 ±0.1	0.157 ±0.004
T max.	0.40	0.016
D1 min.	1.50	0.059
F	11.5 ±0.05	0.453 ±0.002
K max.	6.50	0.256
P2	2.00 ±0.05	0.079 ±0.002
R	50	1.968
W	24.00 ±0.30	0.945 ±0.012
P1	12.00	0.472
Ao, Bo, Ko	0.05 min to 1 max.	0.002 min to 0.039 max.

BASE QUANTITY	2000 pcs.
BULK QUANTITY	2000 pcs.

TAPE & REEL SHIPMENT INFORMATION
REEL SPECIFICATIONS

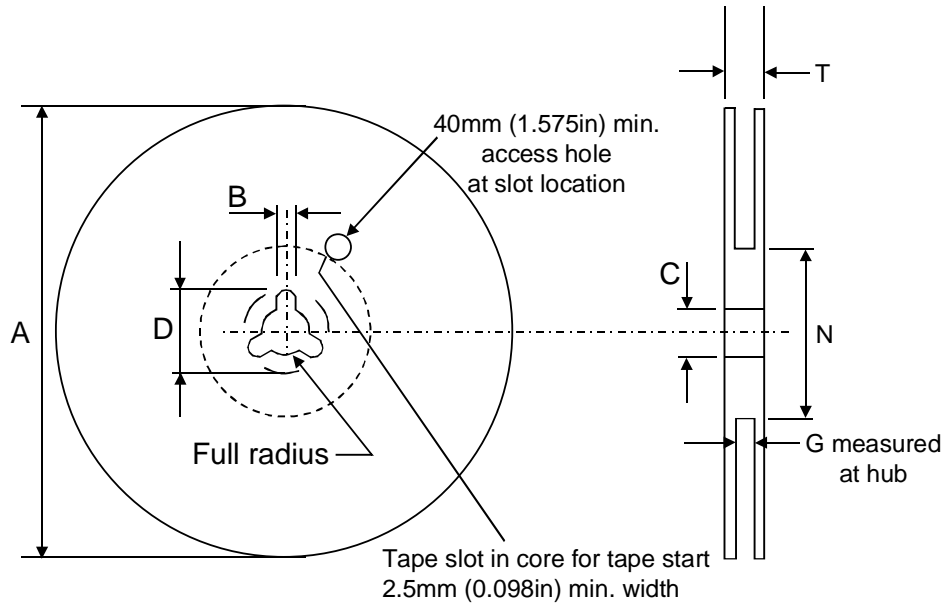

REEL MECHANICAL DATA		
	mm.	inch
Tape size	24.0 ±0.30	0.945 ±0.012
A max.	330.0	12.992
B min.	1.5	0.059
C	13.0 ±0.20	0.512 ±0.008
D min.	20.2	0.795
N min.	60	2.362
G	24.4 +2/-0	0.961 +0.079/-0
T max.	30.4	1.197

FOOTPRINT RECOMMENDED DATA

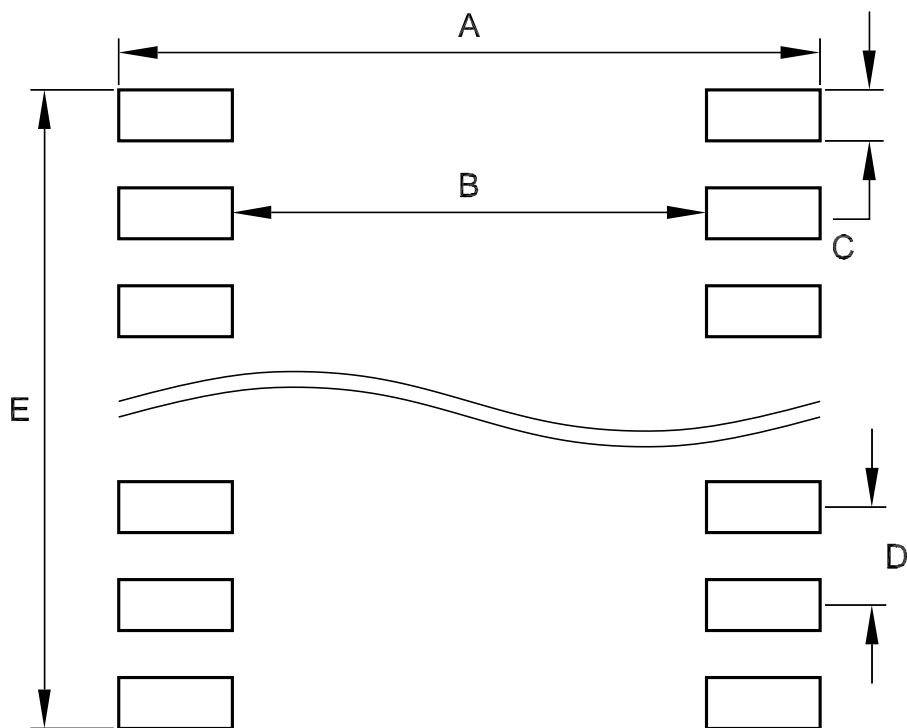

FOOTPRINT DATA		
	mm.	inch
A	8.91	0.351
B	6.82	0.269
C	0.32	0.013
D	0.5	0.019
E	11.8	0.465